

PROPOSED PAD ARRANGEMENT:

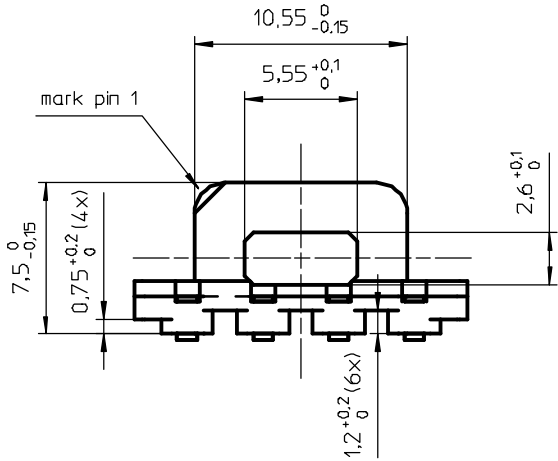

- Coil former material: Sumikon PM-9630 (PF), glass-reinforced
UL file number E41429 - UL94V-0.
- Pin material: CuSn, Sn plated.
- Max. operating temp.: acc. to IEC 60 085 class H, 180°C
- Resistance to soldering heat: acc. to IEC 60 068-2-20 Part 2, Test Tb, method 1B, 350°C-3,5 s.
- Solderability: acc. to IEC 60 068-2-20 Part 2, Test Ta, method 1, 235°C-2s.
- Min. winding area: 15,1 mm²
- Mean length of turn: 24,1 mm.

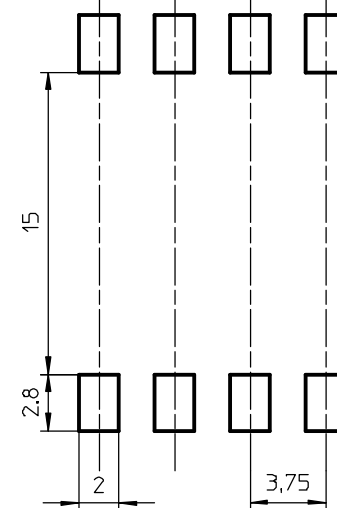
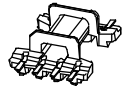

CLASS NO.		03-02-20	
CSHS-EFD15-1S-8P-ZA		4322 021 06081	
NAME NAAM	J. Tjon	SUPERS VERV.	001
MPA	CHECK CONTR.	DATE	03-02-20
Property of Eigendom van		112 - 001	069
© FERROXCUBE 2000		A3	